

Intro to Relative Minors and the Natural Minor Scale

One way to approach learning the natural minor scale is by way of the concept of *relative minor* keys. The diagrams to the right should make this relationship clear. On the left you see the C major scale. To the right is its relative minor, A minor. The two scales share the exact same notes (and so, the same key signature) but they start in different places. This starting point is referred to as the *tonic* of the key or scale. Play each of them, starting and ending on the tonic indicated by the darkened note. Starting on C the scale will sound major; starting on A it sounds minor.

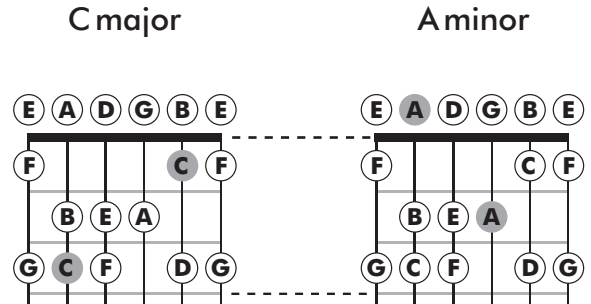

Notice that A is one and a half steps below C. This relationship holds for all relative major/minor keys: *the tonic of the relative minor is one and a half steps below that of its relative major*. Another way of saying the same thing is this: the 6th degree of a major key/scale is the *tonic* of its relative minor. This concept is illustrated by the next set of diagrams. These show the G major scale and its relative minor, Em. But instead of using note names, this time we've included the major scale degrees. As you did above, play each scale starting and ending on the darkened tonic. Start and end on "1" and it will sound major; start and end on "6" and you are playing the *E natural minor scale*. (There are two other common varieties of minor scales we'll discuss elsewhere: the *harmonic* and *melodic* minor scales.)

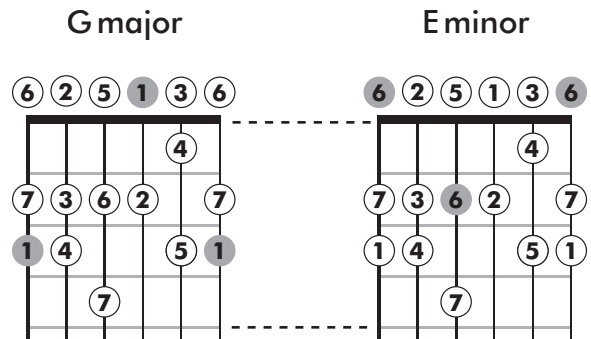

Another way to approach the natural minor scale is on its own terms, as a series of intervals. To the right you see the scale degrees of a natural minor scale and the pattern of intervals between them. (W= whole step; H = half step.) Compared to a major scale, you see that the natural minor scale has a flatted 3rd, 6th and 7th.



The last natural minor scale we'll look at is Dm. This bears an extra look because although it is a common *minor* chord/key, the relative *major* is F, which is not a common guitar key outside of the jazz idiom. Since you may not be familiar with the F major scale, Dm provides a good opportunity to practice building the scale one interval at a time, as shown above. You see the result in the diagram to the right. Notice that the scale consists entirely of naturals with the exception of the 6th scale degree, Bb (3rd string, 3rd fret). Play these same notes from F to F and you'll find that, sure enough, you're playing an F major scale.

D minor

